

8.1.10 Steel bends for the flexible elbow joints (Flex-bends).

Steel bends are produced of seamless steel pipes, of P235GH, according to EN 10217-2.

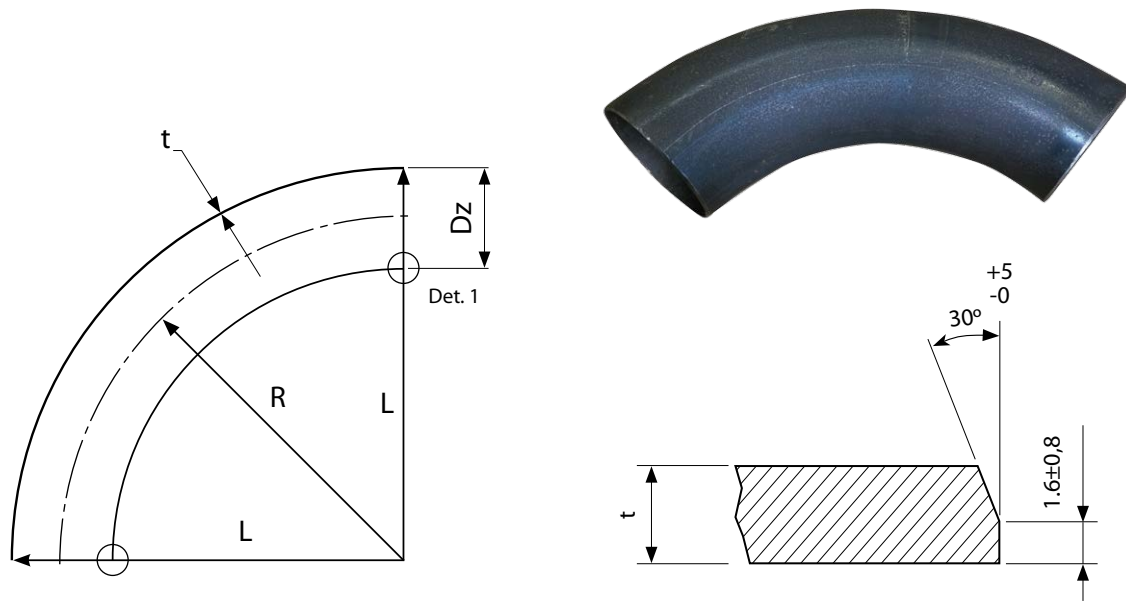

Nominal diameter: DN [mm]	The external diameter: Dz [mm]	The wall thickness t: [mm]	The radius R +5/-5: [mm]	The external radius L +5/-5: [mm]	CATALOGUE No.
20	26,9	2,6	200	213	KS-26926/90
25	33,7	2,6	200	217	KS-33726/90
32	42,4	2,9	200	221	KS-42429/90
40	48,3	2,9	200	224	KS-48329/90
50	60,3	3,2	240	270	KS-60332/90
65	76,1	3,2	240	278	KS-76132/90
80	88,9	3,6	240	284	KS-88936/90
100	114,3	3,6	286	343	KS-114336/90
125	139,7	4,0	349	419	KS-139740/90
150	168,3	4,5	421	505	KS-168345/90

*** Other diameters of bends available on request**

The steel bends are being produced only as 90° elbow. Other angles are to be reached by cutting off the ends of the elbow by required angle.